

# Service Bulletin: AirForce Lift Brackets on Older 6000 Series White

March 25, 2011



The 2011 AirForce lift brackets for White Planters are designed to be compatible with OEM White pneumatic down force brackets. This compatibility gain comes at a cost for older 6000 series row units. The lift brackets are designed to have two constraints:

1. A bolted joint to the parallel arm.
2. A contact constraint against the gusset welded to the bottom of the parallel arm.

Unfortunately, older 6000 series planters (prior to the arrival of heavy duty down force springs) do not have gusset-reinforced parallel arms and therefore do not provide the second constraint for the lift bracket.

Here is a work around for older 6000 planters:

Weld a small block to the underside of the parallel arm to provide a surface for the lift bracket to “push” against. A steel block roughly 1” x 2” x ¼” thick is recommended.

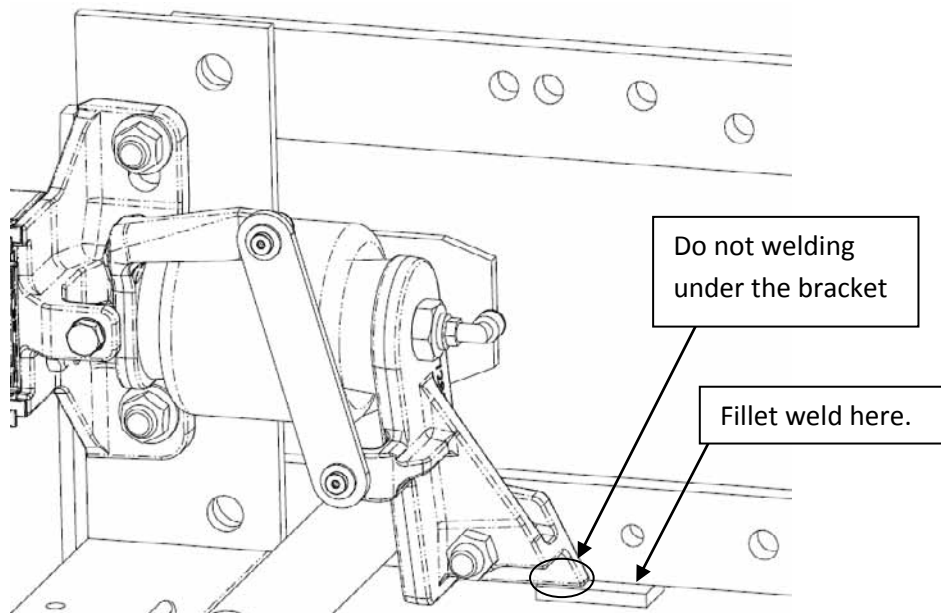

Be careful to avoid welding directly under the lift bracket so that the bracket can sit flush on the surface of the block.

