

CleanSweep Compatibility Guide

Table 1 Cylinder Kit Compatibility

	Row Units											
	JD 7200/7300/17xx					JD 7000	Kinze			White	Case	
	Regular (14" Parallel Arms)		Long (21" Parallel Arms)				Row Cleaner Only	Yetter Single Arm Coulter, UMO 100	Row Cleaner Only			Yetter Single Arm Coulter, UMO 100
Chain Drive	Pro Drive	Row Cleaner Only	Yetter Single Arm, or Dawn Coulter, UMO 100	JD Cast Coulter	Row Cleaner Only	Yetter Single Arm Coulter, UMO 100				Row Cleaner Only	Yetter Single Arm Coulter, UMO 100	
Row Cleaner												
Martin MTS, MTS-XP, MTS-81, MTS-IH	755190	755190	755190	N/A	N/A	755190	N/A	755190	N/A	N/A	755190	755190 ¹
Martin MTR, MTR-XP, MTR-81, MTR-IH	755195 ²	755195 ³	755195 ³	755195 ⁴	755195 ⁵	755225 ⁶	755225 ⁶	755195	755195	755195 ⁷	755225 ⁶	755225 ⁶
Martin BD, BK, BW, BC1H 1360	755200	755200	755200 ⁸	N/A	N/A	755200	N/A	755200	N/A	N/A	755200	755200 ¹
Martin BDC 1360	755205	755205	N/A	N/A	755205 ³	N/A	N/A	N/A	N/A	N/A	N/A	N/A
Yetter 2967-035 (short brkt)	755175	755175	755175	N/A	N/A	755175	N/A	755175	N/A	N/A	755175	N/A
Yetter 2967-035	755180 ²	755180 ³	755180 ³	755180 ⁴	755180 ⁵	755230	755230	755180	755180	755180 ⁷	755230	N/A
Yetter 2967-042, 043	755160	755160	755160 ³	755160 ³	755160 ³	N/A	N/A	N/A	N/A	N/A	N/A	N/A
Yetter 2967-115	755170	755170	755170	755170	N/A	755170	755170	755170	755170	N/A	N/A	N/A
Yetter 2967-007	755185	755185	755185 ³	755185 ³	N/A	N/A	N/A	N/A	N/A	N/A	N/A	N/A
Yetter 2967-029	755210	755210	755210	N/A	N/A	N/A	N/A	N/A	N/A	N/A	N/A	N/A

¹ Mount using bottom hole on base bracket, top hole on rod bracket, flip cylinder upside down, set row cleaner stop bolt high enough so that fittings aren't crushed.

² If JD cast coulter is installed, optional shim (755159) may be necessary to help align the cylinder brackets. For UMO compatibility, see Table 2.

³ Mount using bottom holes on both rod and base brackets, flip cylinder upside down. If JD cast coulter is installed optional shim (755159) may be necessary to help align the cylinder brackets. For UMO compatibility, see Table 2.

⁴ Mount using bottom holes on both rod and base brackets, flip cylinder upside down, and install stop blocks (726530). For UMO compatibility, see Table 2.

⁵ Mount using bottom holes on both rod and base brackets, flip cylinder upside down, and install stop blocks (726530). Optional shim (755159) may be necessary to help align the cylinder brackets. For UMO compatibility, see Table 2.

⁶ Only compatible if the row cleaner frame is mounted in rear pivot holes or the row cleaner base (see Figure 2 on pg 4)

⁷ Kinze coulter bracket must be significantly modified in order to make the base bracket fit. (Requires torching and grinding.)

⁸ If AirForce bracket 726551 is installed, use bottom holes on both rod and base brackets.

Compatible Coulters and Fertilizer Openers

- JC Cast Iron Coulters
- Yetter Single Arm Coulters
- Dawn Single Arm Coulters
- Kinze Double Arm Coulters (See footnote 7 on page 1)
- Martin UMO 100 (note: Martin calls their 1360/UMO combo "BD-UMO". CleanSweep is not compatible with this combination. This is not the same as the BDC 1360, which only mounts to the JD Cast Coulters) See Table 2 for compatibility

Incompatible Coulters and Fertilizer Openers

- Yetter Double Arm Coulters
- JD Double Disk Fertilizer Opener
- JD Single Disk Fertilizer Opener

Table 2 UMO-100 compatibility

CleanSweep Compatibility on C125 MTR row cleaners w/ LH mounted UMO-100				
		1" Left	2" Left	3" Left
755195	3/4" above seed	All Clear	All Clear	Top hole of CS bracket only. Cannot use bottom hole. Row cleaner may not be set any deeper than 3" above seeding depth.
	Even w/ seed	All Clear	All Clear	Top hole, no interference. If using bottom hole, row cleaner may not be set any deeper than 3" above seeding depth
	3/4" below seed	All Clear	All Clear	All Clear
755225	3/4" above seed	All Clear	No Go	No Go
	Even w/ seed	All Clear	No Go	No Go
	3/4" below seed	All Clear	No Go	No Go

Kit Specific Considerations

- 755170
 - Lift force and down force are flip-flopped on this design. That is, the extend side of the cylinder provides the lift force and the retract side provides the down force. Hence, connect the gray tubes to the extend side of the cylinder (base side) and the black tubes to the retract side (rod side).
 - Extra hardware is included to ease installation. Choose between using carriage bolts or hex bolts depending on which installs more easily.
 - Mount cylinder in the hole that corresponds to the position of the row cleaner pivot. E.G: If the row cleaner pivot is in the top most position, use the top hole to mount the cylinder to the base bracket. If the row cleaner is 1/2" below the top position, use the middle hole. If it's 1" below the highest position, use the bottom hole. If it's lower than that use the bottom hole and check to make sure there's clearance around the cylinder (in all functional positions) before using CleanSweep. CleanSweep cannot be used if the row cleaner pivot is lower than 1.5" below the highest position. (see Figure 1)
 - Flip cylinder upside down.

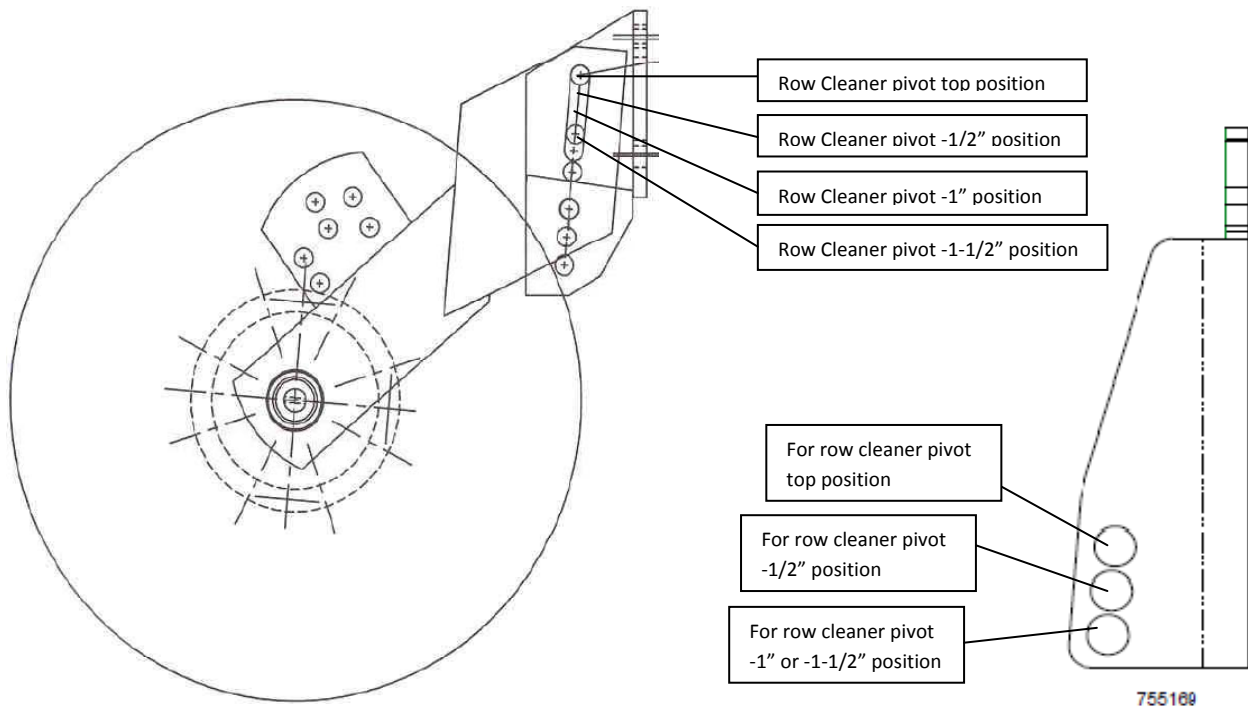

Figure 1 Cylinder Base Mount Configuration for 755170

- 755185
 - The base mounting bracket can be installed without disassembling the row cleaner frame and support plate. This is done by first inserting the upper carriage bolt into the row cleaner face plate bracket and then slipping the cylinder base bracket in behind the carriage bolt. Simultaneously, you will need to rotate the cylinder bracket so that it can slide in behind and wrap around the row cleaner support plate.
- 755210
 - Must install pin on base bracket before installing base bracket on row cleaner. Install pin from the right side (when facing toward the front of the planter)
 - Pressure range for this model is much lower than other row cleaners due to its compact design and lighter weight. Expect to run much lower pressures such as in the range of +/- 20 psi
- 755225 and 755230
 - Lift force and down force are flip-flopped on this design. That is, the extend side of the cylinder provides the lift force and the retract side provides the down force. Hence, connect the gray tubes to the extend side of the cylinder (base side) and the black tubes to the retract side (rod side).
 - Top holes in the rod bracket are not usable on this design
 - The rear elbow fitting (726111) on the air cylinder should be replaced with the straight fitting (726107) included in this kit.

Cylinder Pivot Hole Selection

The following guidelines are intended to help you select which holes to use to mount the cylinder. Be sure to check the configuration specific instructions (see pg 1-3) before assuming you can use the default hole positions (listed below). Some planter/row cleaner combinations require only certain holes to be used. Failure to follow these instructions may result in damage to the cylinders, fittings, brackets, or planter components.

The default hole positions listed in Table 2 (see pg 4) are recommended assuming that your planter/row cleaner configuration does not have other hole specifications (see pg 1-3). **Regardless, it is always important to raise and lower both the row unit and the row cleaner to their extreme positions to check for pinch points around the tubing and clearance for the cylinder and fittings.** Kits 755180, 755195, 755205, 755225, and 755230 have an array of holes from

which to choose. For these kits or to simply understand the advantages of using alternative pivot holes, see the **Cylinder Pivot Hole Detailed Guide** on pg 4-5. As a simple rule of thumb, positioning the cylinder farther away from the row cleaner pivot point will result in more applied force on the row cleaner. However, be careful not to confuse more “applied force” with more “down force.” Since the cylinder can apply either lift force or down force, more “applied force” may actually result in less “down force”. It all depends on which direction you intend to apply the force.

Table 3 Default Pivot Hole Positions

Default Pivot Hole Positions ⁹		Base Default	Rod Default
755190	Martin C125 MTS, MTS-XP, MTS-81	top	top
755195 ¹⁰	Martin C125 MTR, MTR-XP, MTR-81	top	top
755200	Martin BD, BK, BW 1360	top	top
755205	Martin BDC 1360	top	top
755175	Yetter 2967-035 (short brkt)	top	top
755180 ¹⁰	Yetter 2967-035	top	top
755185	Yetter 2967-007	top	top
755160	Yetter 2967-042, 2967-043	top	top
755170	Yetter 2967-115	top	n/a
755210	Yetter 2967-029	bottom	top
755225 ¹⁰	Martin C125 MTR, MTR-XP, MTR-81 (Low)	bottom	bottom
755230 ¹⁰	Yetter 2967-035 (Low)	bottom	bottom

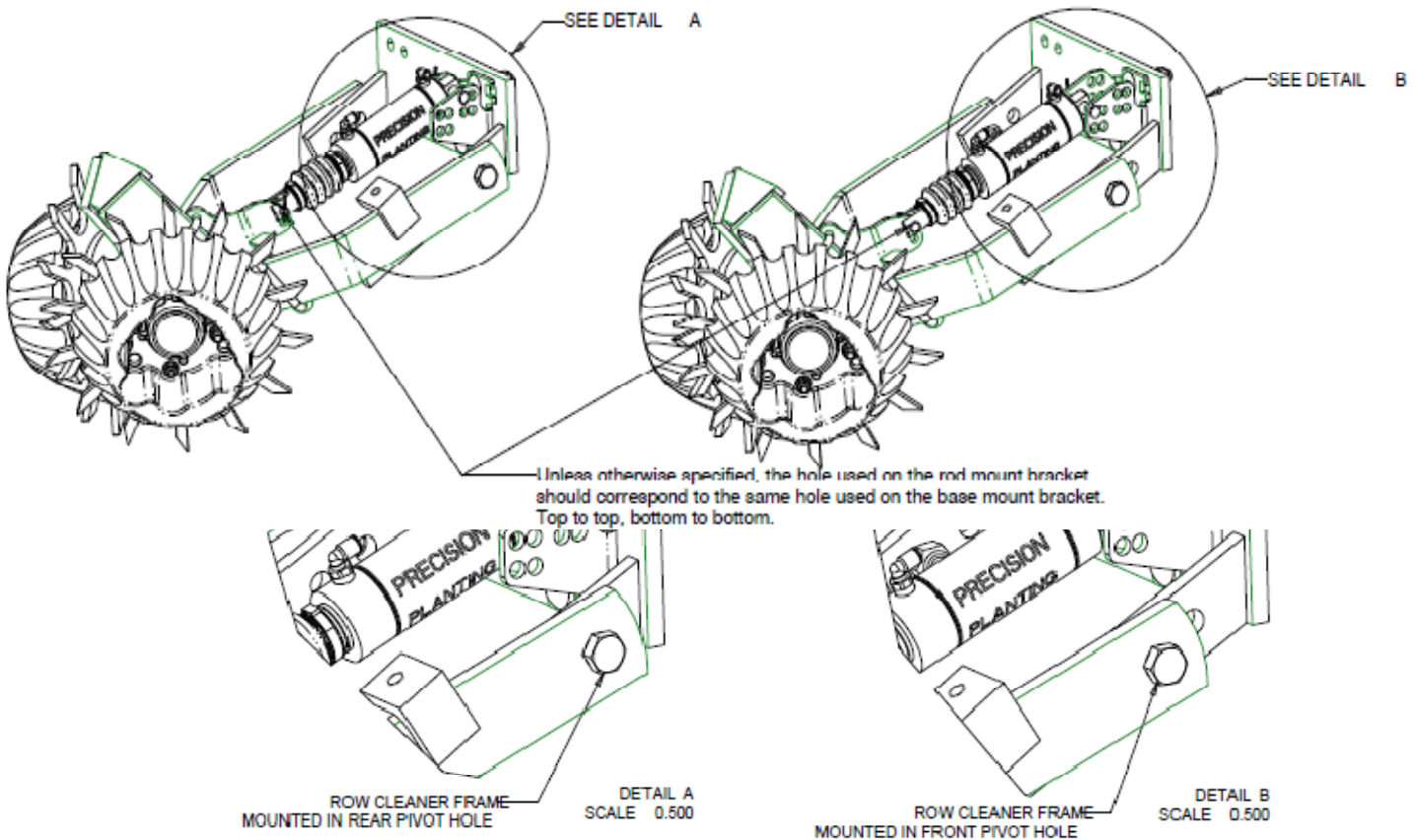

⁹ Be sure to check configuration specific instruction (see pg 1-3) before assuming the “default” holes are right for your configuration. Failure to do so may result in damage to the air cylinder, fittings, or other components.

¹⁰ See Next page for more details about pivot hole selection

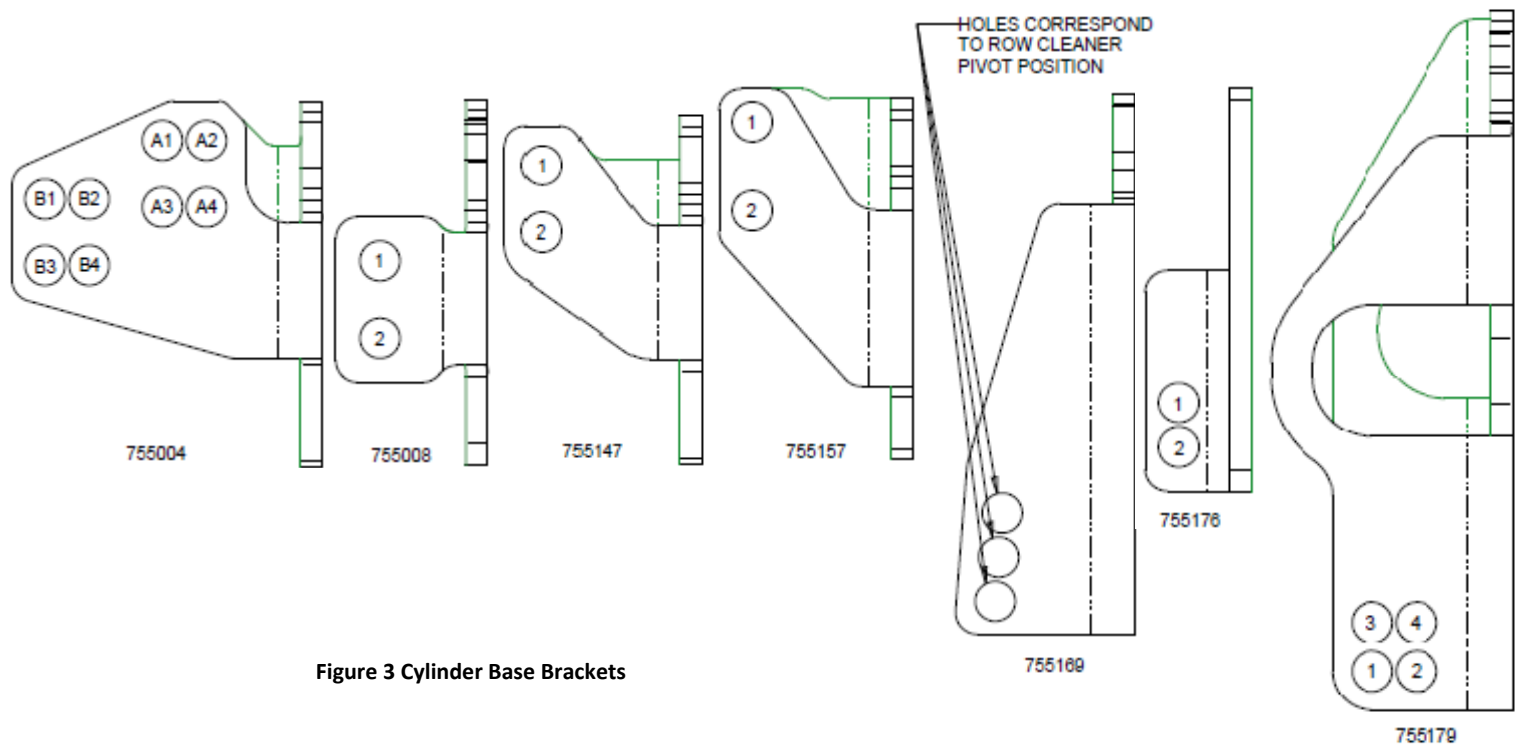

Figure 3 Cylinder Base Brackets

Cylinder Pivot Hole Detailed Guide (see Figure 2 and 3)

- **A/B Range Holes**
 - A Range Holes: To be used with Martin MTR when the row cleaner frame is mounted in the rear pivot hole and with Yetter 2967-035 (see Figure 2, Detail A)
 - B Range Holes: To be used with Martin MTR when the row cleaner frame is mounted in the front pivot holes (see Figure 2, Detail B)
- **Top/Bottom Holes**
 - Rule of thumb: The farther away the cylinder is from the row cleaner pivot point, the greater the magnitude of the force applied by the cylinder (either up or down)
 - Holes 1 and 2:
 - To be used on rows where more down force is desired when force will generally be applied in the down direction.
 - To be used on rows where less down force is desired when force will generally be applied in the up direction.
 - See Row Cleaner Compatibility Guide for compatibility restrictions on particular models.
 - Holes 3 and 4:
 - To be used on rows where less down force is desired when force will generally be applied in the down direction
 - To be used on rows where more down force is desired when force will generally be applied in the up direction
- **Front/Back Holes**
 - Holes 1 and 3 (Front Holes): To be used if the cylinder base bracket is mounted directly to the row cleaner face plate bracket
 - Holes 2 and 4 (Back Holes): To be used if bracket is mounted on top of another attachment (e.g. row unit mounted coulter, UMO 100, etc.)

Treader Wheel Compatibility

- Not compatible with JD 1770NT planters. There is not sufficient clearance in between the transport wheel frames.
- Make sure you have enough clearance between transport frames. With the 3.5" wheels installed, the row cleaner is between 15.5" and 16.5" at its widest point, depending on the specific row cleaner.
- We recommend using treader wheels with clean sweep. However, we do not recommend mixing and matching different wheel sizes, so if the 3.5" wheels don't fit your planter, use 1.75" wheels on all rows instead.
- For Yetter wheels, be sure to align grease slot on all components (see Figure 4)

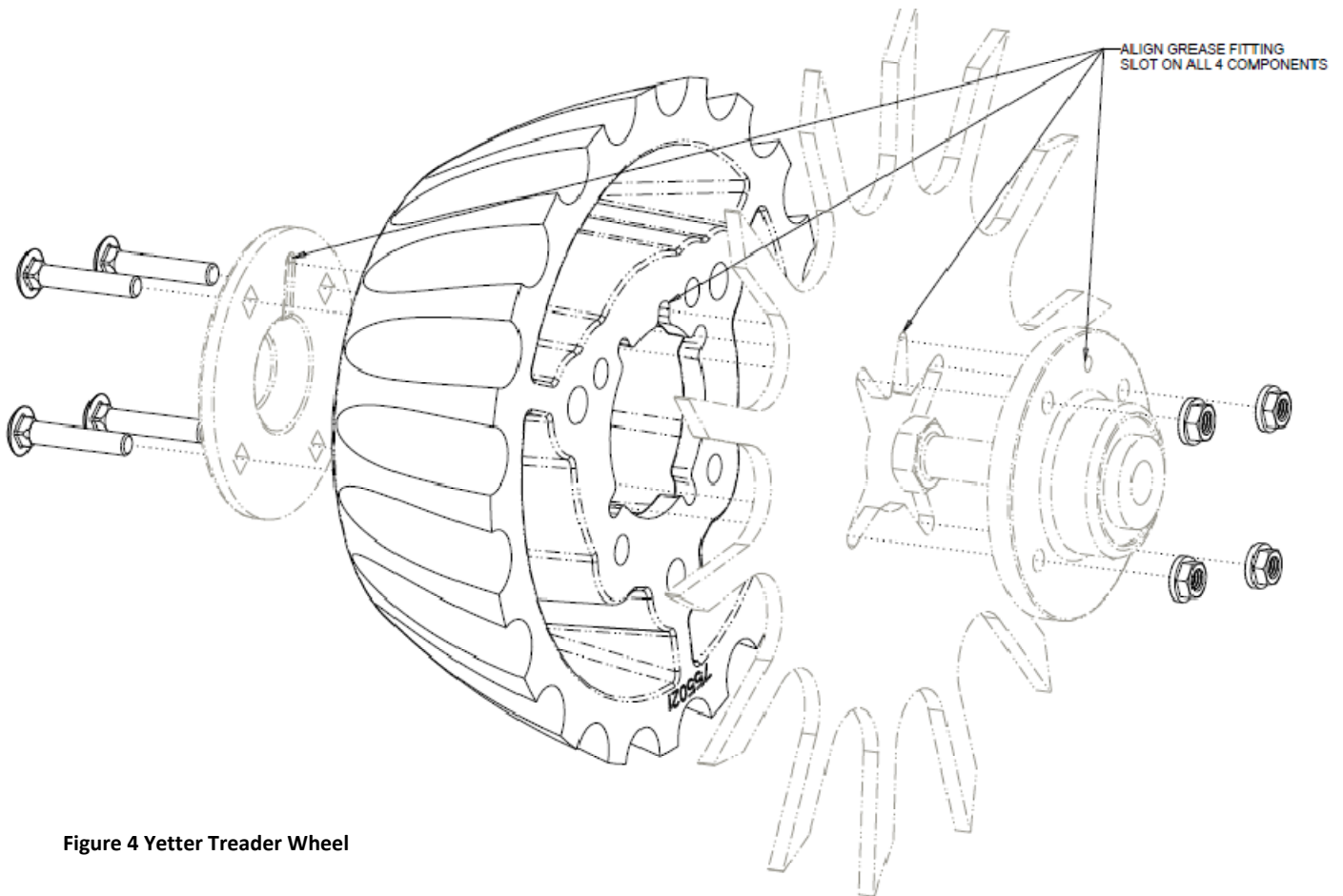

Figure 4 Yetter Treader Wheel