

Row Unit Conversion Instructions

Part#: 726690 - CNH Lift Conversion

Planter Models:CNH 12XX series Planters
To Convert From Existing Springs:.....CNH Pneumatic Air Springs
Resulting Forces Controlled:.....Down & Lift
With Conversion Kit:.....726690

EXISTING SPRINGS

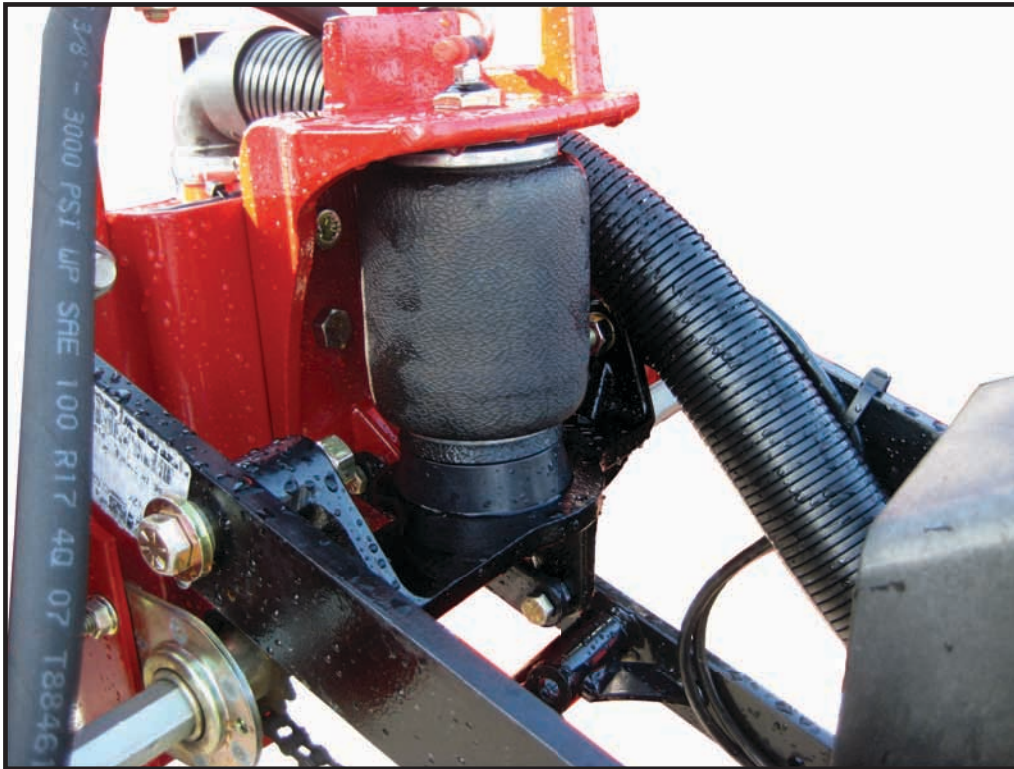

This conversion process applies to the 1200 family of planters with **Regular** (14") parallel arms. The examples shown below are diagrams for a planter with regular parallel arms; some components shown here may not apply to your particular planter. Special notes will be made throughout the following instructions to assist with most individual model needs. Images illustrating a completed row unit conversion are located at the end of these instructions.

Row Unit Conversion Instructions (Continued)

Part#: 726690 - CNH Lift Conversion

Conversion Kit Components

Item	QTY	Part Number	Part Name	Description
1	1	726101	Air Spring	Air Bag (Lift)
2	1	726672	Bracket	Air Spring Head Mount
3	1	726673	Bracket	Air Spring Base Mount
5	1	726699		Hardware Kit

Quantities are given per row.

Hardware Pack Components

Item	QTY	Part Number	Part Name	Description
6	2	13005	Bolt	1/4" X 1" GRD5 Hex Bolt ZN
7 †	1	13105	Bolt	3/8" X 1" GRD5 Bolt ZN
8	3	13206	Bolt	1/2" X 1.125" GRD5 Bolt ZN
9	2	13209	Bolt	1/2" X 1.5" GRD5 Bolt ZN
10	3	33078	Washer	1/4" SAE Flat ZN
11	2	33086	Washer	1/2" SAE Flat ZN
12	1	36214	Hex Jam Nut	5/8" Hex Nut ZN
13 †	1	36266	Hex Jam Nut	3/4" Hex Nut ZNCL
14	2	37260	Hex Nut	1/4" Top Lock Nut ZN
15	3	37268	Hex Nut	1/2" Top Lock Nut ZN
16 †	1	726113	Tee	1/8" NPT X 1/4" PTC Tee
17	2	726574	Bushing	1/4"ID X 1/2"OD X 0.23L
18	1	726681	Link	Case 14" Parallel Arm Stabilizer
19	1	726689	Stud	Case Air Spring Base Connector
20	2	726691	Bushing	1/2"ID X 7/8"OD X 0.550"L
21	1	726698	Male Elbow	45Deg 1/8"NPT X 1/4" PTC Elbow

Quantities are given per row.

† Not used in this configuration. Note, some components of the 726699 Hardware Kit may not be necessary in all cases; this is a universal hardware kit that is common to several assemblies.

Recommended tools (not provided):

Open end wrenches: 7/16", 9/16", 3/4", 15/16", 1-1/8" - or suitable crescent wrench (s)

Sockets (Deep well recommended): 7/16", 9/16", 3/4", 15/16", 1-1/8"

Torque Wrench

Row Unit Conversion Instructions (Continued)

Part#: 726690 - CNH Lift Conversion

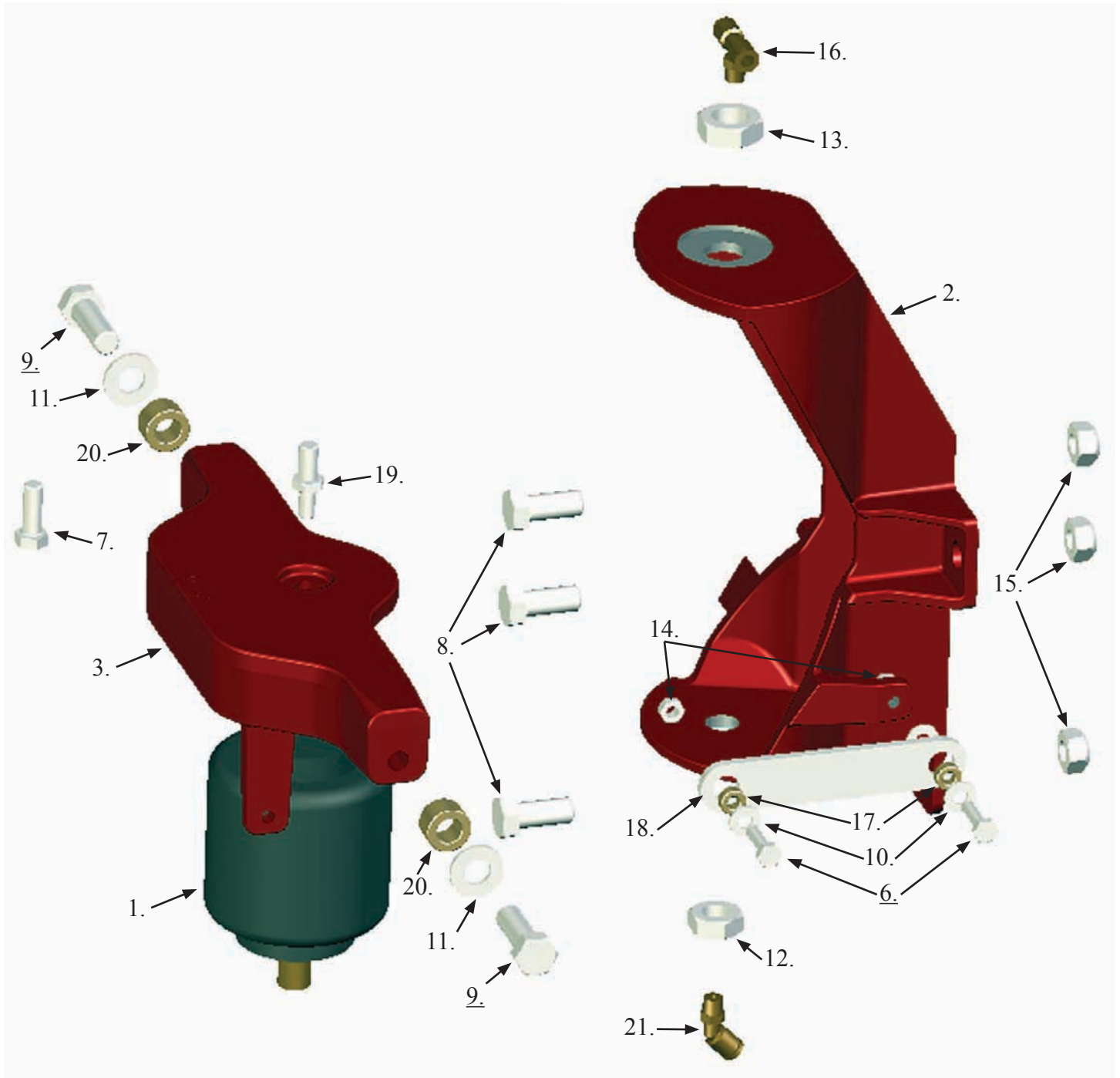

Row Unit Conversion Instructions (Continued)

Part#: 726690 - CNH Lift Conversion

Step 1:

Begin installation by removing air pressure from the existing springs system. Once the tension is removed, prepare for the conversion process by removing the existing spring system (refer to OEM owner's manual or your local representative for instruction on this process). Set pieces aside, save the CNH Air Spring.

Step 2:

Now that the row unit is ready to accept new components, begin by securing the Case Air Spring Head Mount (726672) to the 'W' plate on the planter frame using the 1/2" X 1.125" GRD5 Bolts (13206). The wide holes are only used on Precision Planting's extension brackets.

Note: It may be necessary to shift the vac tube manifold to the left or right in order to clear the Head Mount bracket with the vac hose.



Case Air Spring Head Mount (726672)

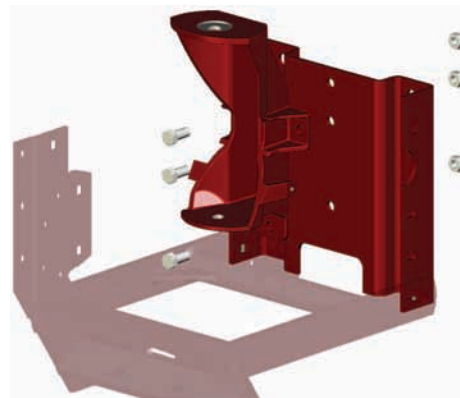

Case Air Spring Head Mount (726672)
and 1/2" X 1.125" GRD5 Bolts (13206)

Step 3:

Continue the conversion process by pre-assembling the Lift Air Spring (726101) and CNH Down Air Spring to the Air Spring Base Mount (726679) using the Case Air Spring Base Connector Stud (726689). Holding the Base Mount bracket and Lift Air Spring thread the Connector Stud in the base of the Lift Air Spring as shown. Tighten to 4-5lb-ft of torque. Next, thread the Case Down Air Spring onto the Connector Stud. Hand Tighten as best as possible, but **DO NOT** use wrenches or pliers on the spring to tighten the spring any further. This may damage the spring and is unnecessary.

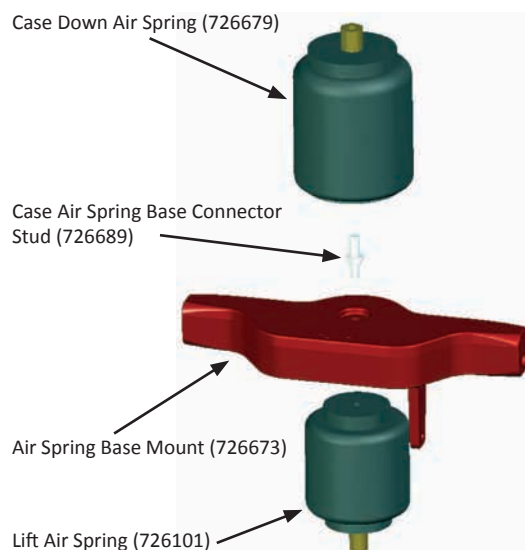

Row Unit Conversion Instructions (Continued)

Part#: 726690 - CNH Lift Conversion

Step 4:

Next, install the Air Spring Assembly into the Head Mount from step 2. Angle and compress the Lift Air Spring to align the brass stud with the hole in the lower portion of the Head Mount. Once the Lift Air Spring is in place, repeat the process of compressing and angling the Case Down Air Spring to align with the hole in the upper portion of the Head Mount. It may be helpful, prior to placing the Down Air Spring, to thread the 5/8" Hex Jam Nut (36214) onto the brass stud of the Lift Air Spring and finger tighten. With the Air Spring Assembly installed in the Head Mount, securely fasten the Base Mount to the parallel arms using two – 1/2"X1.5" GRD5 Bolts ZN, two – 1/2"SAE Flat Washers ZN, two – 1/2"ID X 7/8"OD X 0.550"L Bushings. See image at right for placement. Once both Air Springs have been placed in their respective locations; thread and tighten onto their respective studs the 5/8" Hex Jam Nut (36214) – Lift Air Spring; and the 3/4" Hex Jam Nut (36266) – Case Down Air Spring.

5/8" Jam Nut for Lift Air Spring: 10lb-ft of torque

3/4" Jam Nut for Down Air Spring: 30lb-ft of torque.

DO NOT OVERTIGHTEN

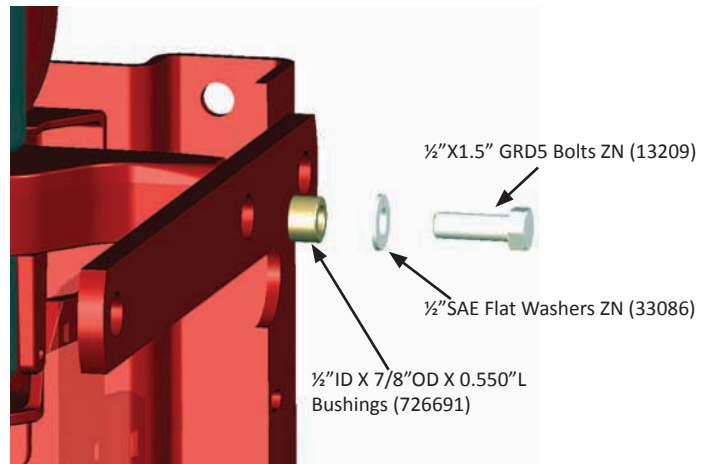
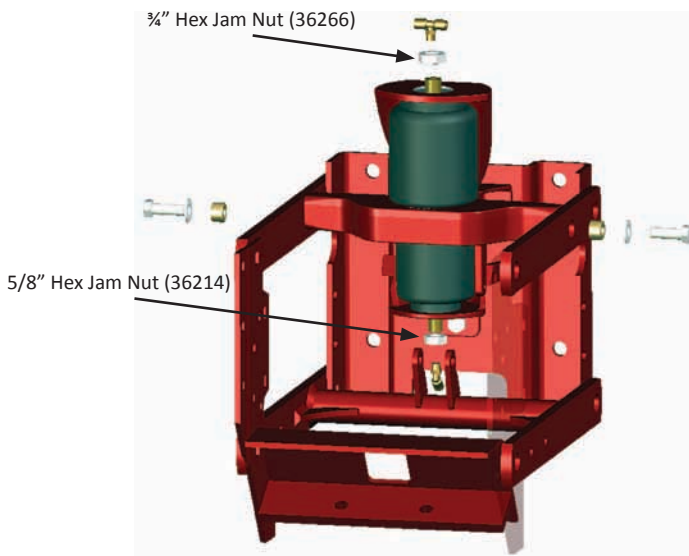

Note: Use image as base for next couple steps with specific insets.

Row Unit Conversion Instructions (Continued)

Part#: 726690 - CNH Lift Conversion

Step 5:

Next install the Case 14" Parallel Arm Stabilizer Link between the Air Spring Head Mount (726672) and the Air Spring Base Mount (726673). **See *Img. A*** Secure the Stabilizer Link using the supplied hardware:

- Two – ¼" X 1" GRD 5 Bolt ZN (13005)
- Three – ¼" SAE Flat Washers (33078)
- Two – ¼" Top Lock Nut ZN (37260)
- Two – ¼"ID X ½"OD X 0.23"L Bushings (726574)

Note: only two washers are required for installation. A third washer is included and may be used to shim out the link if it is necessary to improve alignment (installed behind Stabilizer Link on Head Mount casting).

Note Location/Placement of 3rd Washer

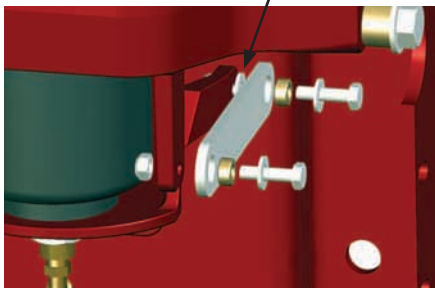

Img. A



Img. B

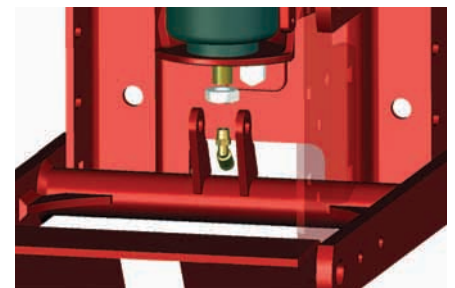

Img. C

Complete the installation by installing the fittings for the air lines for the down and lift circuits. Thread the 1/8" NPT X 1/4" PTC Tee into the top of the Case Down Air Spring. Tighten to "hand tight + 1 turn." **See *Img. B***

Thread the 45degree 1/8" NPT X 1/4" PTC Male Elbow (726698) fitting into the brass stud on the Lift Air Spring. Tighten to "hand tight + 1 turn." **See *Img. C***.

When installing 1/4" tubing, be sure that the 45° elbow faces forward to prevent damage to the fitting where it could collide with the PA.

Note: these pneumatic fittings come with a thread sealant pre-installed on the threads. If it becomes necessary to replace these, or they are removed and re-installed multiple times, the application of a suitable thread sealant should be made.

Completed Row Unit Conversion

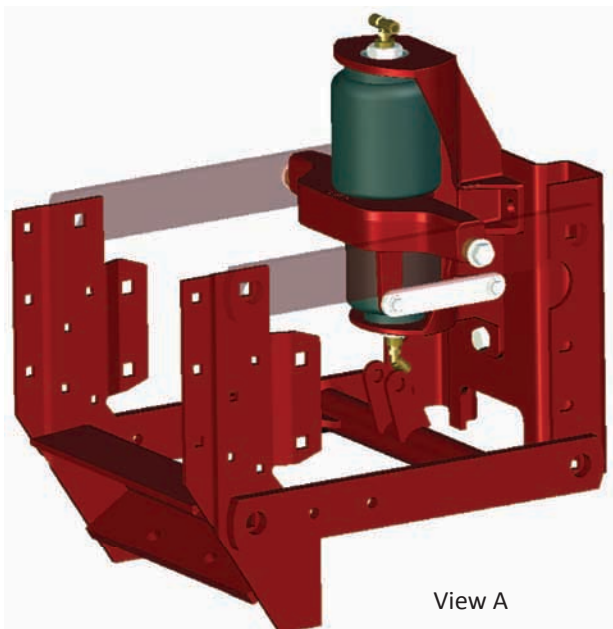

View A

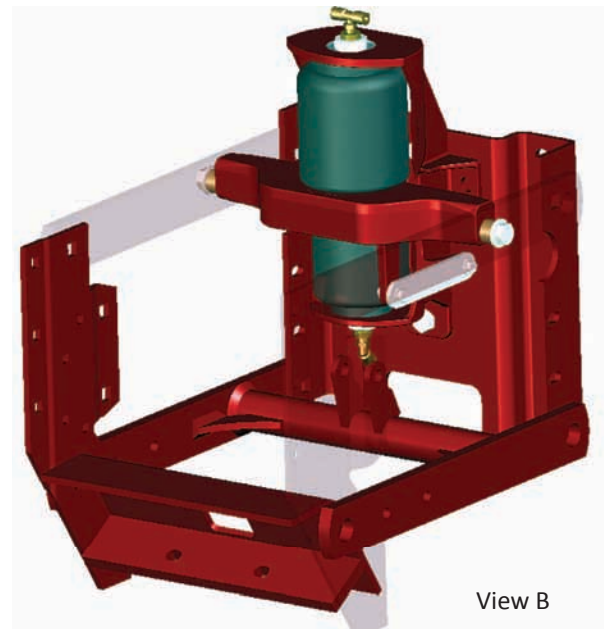

View B