

# 726300













## LINES AND FITTINGS

### 8 Row - LIFT CIRCUIT

QTY	PART NUMBER	PART NAME	DESCRIPTION	Notes
1	726326	TUBING	3/8 RED 25'	A
1	726314	TUBING	1/4 RED 50'	B
1	726298	Y FITTING	3/8 x 1/4 x 1/4 PTC	C
2	726103	PLUG	1/4 PTC	D
12	63128	TIE STRAP	12" UV BLACK	E
1	726617	RECEIVER	80 CUBIC INCH, LIFT	F
2	63461	TIE STRAP	31.5" UV BLACK	F
2	726110	ELBOW	1/4" NPT x 3/8 PTC SWIVEL 90	F
1	726273	ELBOW	3/8 PTC	A
3	726104	PLUG	3/8 PTC	

NOTES:	
A	To be used between enclosure and "Y" fittings
B	To be cut to length as required during installation for use between row units
C	To be used between 3/8" tubing and 1/4" tubing, use as required
D	Use as required at end of planter sections in "T" fitting on top of lift air bags
E	Use as required to secure tubing
F	Fittings to be installed into reservoir during installation, large tie straps secure receiver to any available structural element of planter

### LEGEND

	Pneumatic Spring; Down or Lift
	1/8" NPT X 1/4" X 1/4" Brass PTC Tee
	1/8" NPT X 1/4" PTC Tee
	1/4" Brass PTC Tee
	3/8" X 1/4" X 1/4" PTC Tee
	3/8" PTC Tee
	3/8" PTC 90° Elbow
	1/4" NPT Male X 3/8" PTC Straight
	80 cubic inch Lift Circuit Receiver tank
	PTC plug; 3/8" or 1/4"
	3/8" Line (Black or Red/Silver)
	1/4" Line (Black or Red/Silver)

# Plumbing Installation

---



**This process should be done with the planter raised, half folded for transport, and the row units fully extended down.**

The following pages contain images of suggested methods of routing the air lines for your new 20/20 Air-Force. Due to the wide variety of planter/row unit configurations and accessories available, you should adapt the installation as necessary for your planter. The primary concern is the security of the lines themselves. The lines should be fastened to the planter in a manner that allows full range of motion/clearance of the row unit. Special caution should be taken around rows at break or fold points of the planter as it folds to and unfolds from transport mode. Extra lengths of slack or alternative routing may be necessary.

- ◆ The supplied fittings should have pre-existing thread sealant - ready to install - for ease of installment. Always use Thread Tape when installing air fittings that do not have this
- ◆ Black Tubing - used for the Down Force Circuit
- ◆ Red / Silver Tubing - used for the Lift Force Circuit
- ◆ 3/8" lines (Black or Red/Silver) - used for the main line **from** the Compressor Module **to** groups of rows, usually on the main draw bar of the planter
- ◆ 1/4" lines (Black or Red/Silver) - used **from** the main line **to** and **between** the individual row unit Air Bags
- ◆ Secure the Air Lines using the supplied zip tie-straps - do not pinch the line closed when cinching tight
- ◆ The 1/4" lines should be routed back to and secured to the main bar or to existing bundles of wires/hoses of the planter between row units
- ◆ Most 30" row configurations should need between 34 to 42 inches of 1/4" line between Down Force Air Bags. **Do not** pre-cut the line, measure lay-out each length individually.
- ◆ Lift Circuit kits containing 1 extra brass 1/4" PTC Tee per row will require lengths of the 1/4" line from the connector on top of the Lift Bag to the 1/4" PTC Tee placed on the main Draw Bar.
- ◆ All Lift Circuits will require the use of one or multiple 80 cubic inch Air Receiver Assemblies along the 3/8" line. These are used to dissipate the force created in the Lift circuit as the planter is raised and the weight of the row unit is transferred to the Lift bags.
- ◆ The color of the tubing is for ease of circuit identity only and has no bearing on capacities.

After completion of the **FIRST** row and **PRIOR** to continuing to other rows, check for clearance of, and lack of pinch points on all lines and fittings. This should be done by completely raising and lowering the planter to flex the row unit through its entire range of motion.

Row Configuration: 8 Row, any spacing

Transport/ Fold: N/A

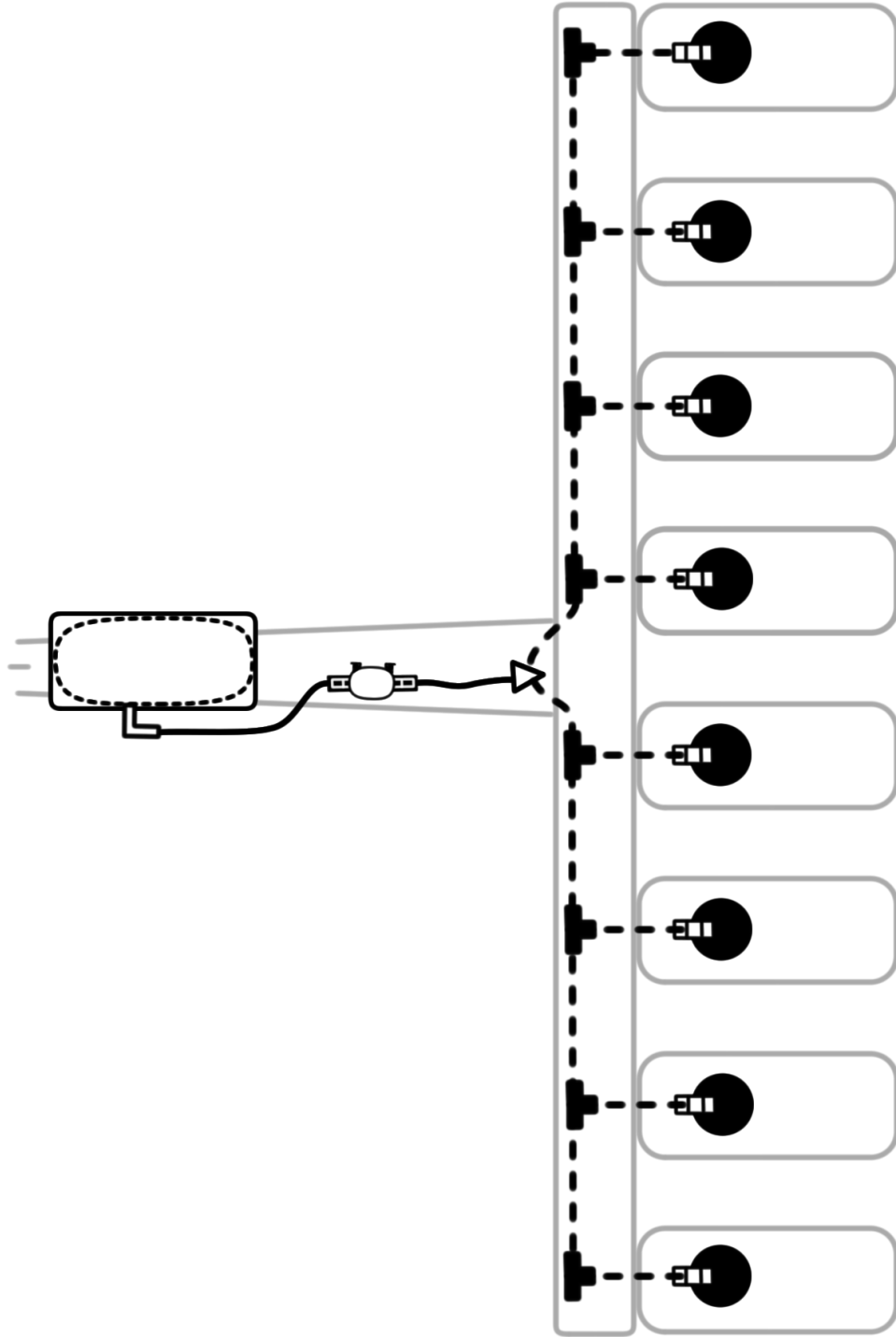

Row Configuration: 8 Row, any spacing  
Transport/ Fold: Lift & Twist

